

isc Silicon PNP Power Transistor

2SA968 A B

DESCRIPTION

- With TO-220 packaging
- Complement to Type 2SC2238 A B
- Minimum Lot-to-Lot variations for robust device performance and reliable operation

APPLICATIONS

- AC-DC motor control
- Electronic ignition
- Alternator regulator

ABSOLUTE MAXIMUM RATINGS(T_a=25°C)

SYMBOL	PARAMETER	VALUE	UNIT	
V _{CBO}	Collector-Base Voltage	2SA968	-160	V
		2SA968A	-180	
		2SA968B	-200	
V _{CEO}	Collector-Emitter Voltage	2SA968	-160	V
		2SA968A	-180	
		2SA968B	-200	
V _{EBO}	Emitter-Base Voltage	-5	V	
I _C	Collector Current-Continuous	-1.5	A	
I _E	Emitter Current- Continuous	-1.5	A	
P _C	Total Power Dissipation @ T _C =25°C	25	W	
T _J	Junction Temperature	150	°C	
T _{stg}	Storage Temperature Range	-55~150	°C	

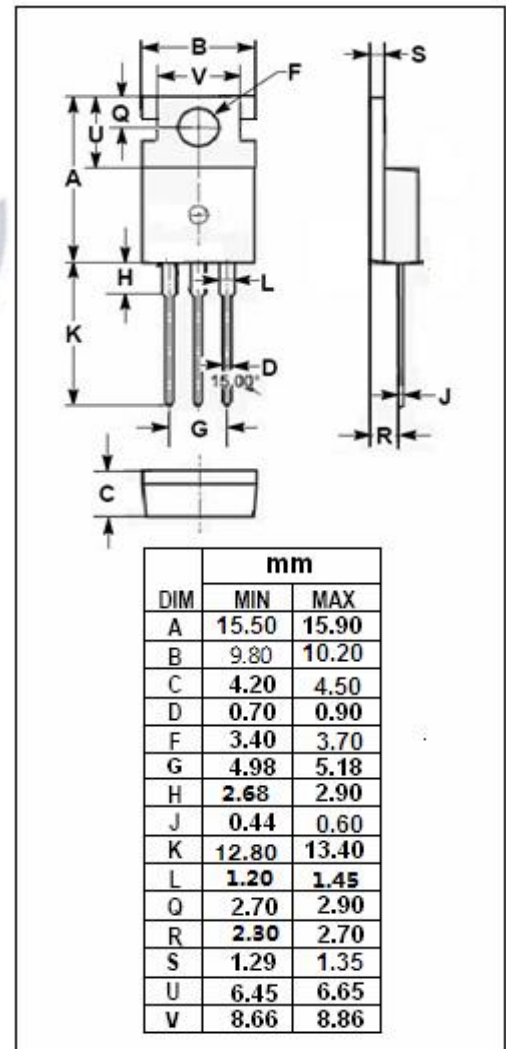
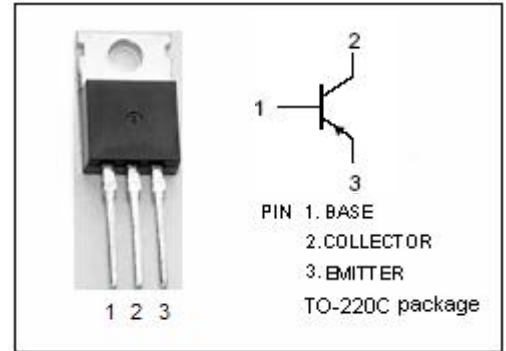

isc Silicon PNP Power Transistor**2SA968 A B****ELECTRICAL CHARACTERISTICS** $T_c=25^\circ\text{C}$ unless otherwise specified

SYMBOL	PARAMETER	CONDITIONS	MIN	TYP.	MAX	UNIT
$V_{(BR)CEO}$	Collector-Emitter Breakdown Voltage	$I_C = -10\text{mA}$; $I_B = 0$	2SA968	-160		V
			2SA968A	-180		
			2SA968B	-200		
$V_{(BR)EBO}$	Emitter-Base Breakdown Voltage	$I_E = -1\text{mA}$; $I_C = 0$	-5			V
$V_{CE(sat)}$	Collector-Emitter Saturation Voltage	$I_C = -0.5\text{A}$; $I_B = -50\text{mA}$			-1.5	V
$V_{BE(on)}$	Base-Emitter On Voltage	$I_C = -0.5\text{A}$; $V_{CE} = -5\text{V}$			-1.0	V
I_{CBO}	Collector Cutoff Current	$V_{CB} = -160\text{V}$; $I_E = 0$	2SA968		-1.0	μA
		$V_{CB} = -180\text{V}$; $I_E = 0$	2SA968A			
		$V_{CB} = -200\text{V}$; $I_E = 0$	2SA968B			
I_{EBO}	Emitter Cutoff Current	$V_{EB} = -5\text{V}$; $I_C = 0$			-1.0	μA
h_{FE}	DC Current Gain	$I_C = -0.1\text{A}$; $V_{CE} = -5\text{V}$	70		240	
C_{OB}	Output Capacitance	$I_E = 0$; $V_{CB} = -10\text{V}$; $f_{test} = 1\text{MHz}$		30		pF
f_T	Current-Gain—Bandwidth Product	$I_C = -0.1\text{A}$; $V_{CE} = -10\text{V}$		100		MHz

◆ **h_{FE} Classifications**

O	Y
70-140	120-240